

FSL-800MDS Electromagnetic Lock Datasheet



Specifications

- Operating voltage: 12/24Vdc (auto-switchable)
- Current draw: 500mA/12Vdc; 250mA/24Vdc
- Operating Temperature: -10~+55degC
- Humidity: 0~95% non-condensing
- Holding force: 363Kg (800lbs)

Optional Accessories

- LZ Bracket for inswing door (FSL-LZ800M)
- U Bracket for glass door

Wiring Diagram

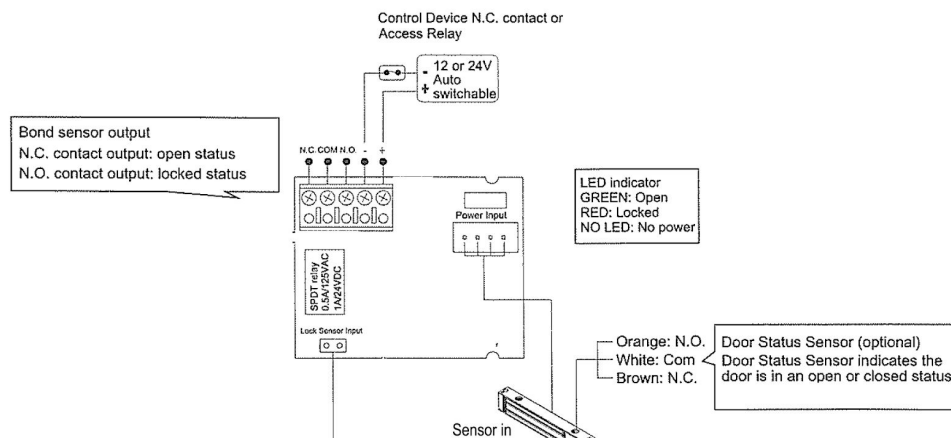

HEAD OFFICE

U1, 37-39 Green St.
Banksmeadow, NSW. 2019
p. 61 2 9700 1700
f. 61 2 9700 1955
sales@fermaxaus.com.au

QLD OFFICE

U11, 8 Fortitude Cres.
Burleigh Heads, QLD. 4220
p. 61 7 5520 2266
f. 61 7 5520 4591
qld@fermaxaus.com.au

VIC OFFICE

U30, 640-680 Geelong Rd.
Brooklyn, VIC. 3012
p. 61 3 9314 2220
f. 61 3 9314 7772
vic@fermaxaus.com.au

WA OFFICE

PO Box 587
Balcatta, 6914
m. 0438 700 101
wa@fermaxaus.com.au

NZ OFFICE

PO Box 112 110
Penrose, 1642
m. 64 27 566 0222
p. 64 9 337 6229
nz@fermaxnz.co.nz

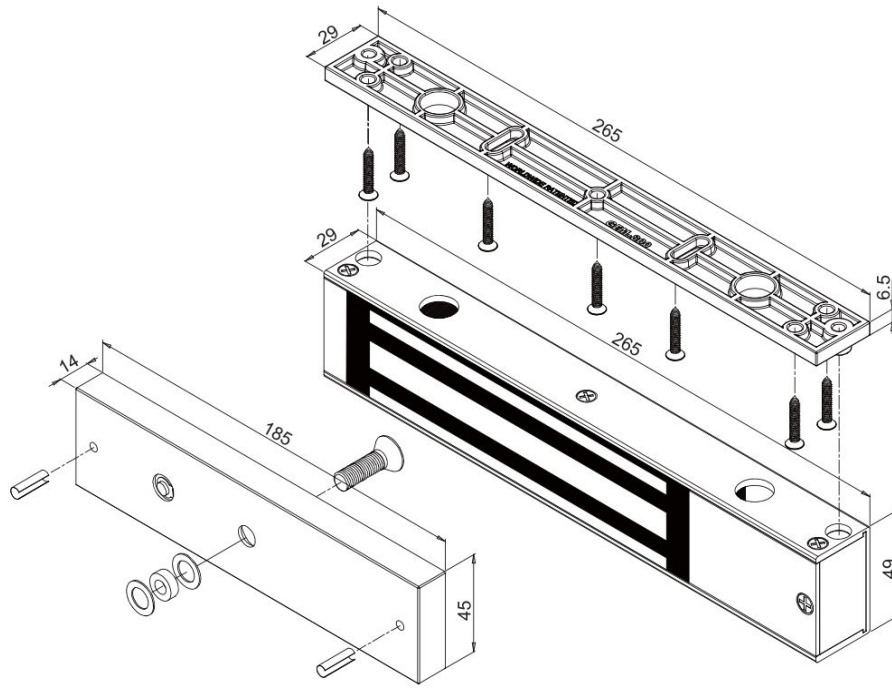

Unit: mm

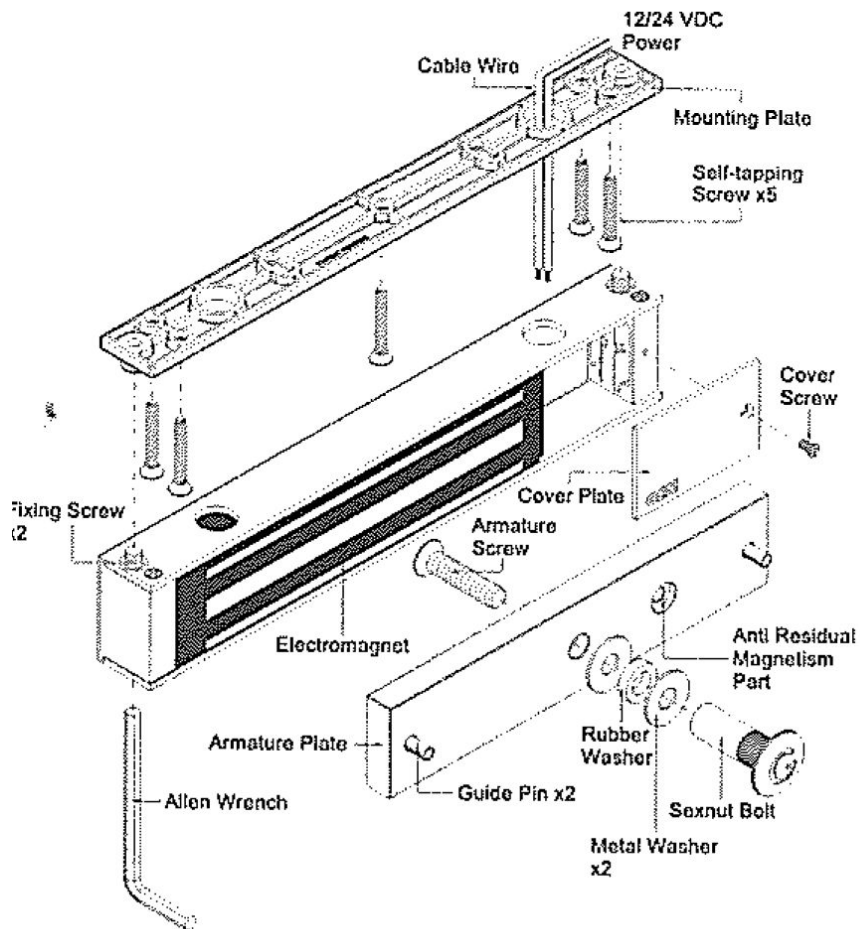

HEAD OFFICE

U1, 37-39 Green St,
Banksmeadow, NSW. 2019
p. 61 2 9700 1700
f. 61 2 9700 1955
sales@fermaxaus.com.au

QLD OFFICE

U11, 8 Fortitude Cres,
Burlleigh Heads, QLD. 4220
p. 61 7 5520 2266
f. 61 7 5520 4591
qld@fermaxaus.com.au

VIC OFFICE

U30, 640-680 Geelong Rd,
Brooklyn, VIC. 3012
p. 61 3 9314 2220
f. 61 3 9314 7772
vic@fermaxaus.com.au

WA OFFICE

PO Box 587
Balcatta, 6914
m. 0438 700 101
wa@fermaxaus.com.au

NZ OFFICE

PO Box 112 110
Penrose, 1642
m. 64 27 566 0222
p. 64 9 337 6229
nz@fermaxnz.co.nz